

SUNRAY™

MOBILE OPS SURVEILLANCE TOWERS

SOLAR-POWERED | OFF-THE-GRID

Deter theft and vandalism at any outdoor location, including job sites, parking lots, events and more.

National Signal's **Sunray™ Mobile Operations Surveillance Towers** offer compact, portable, and eco-friendly security solutions. Designed for easy transport and rapid deployment, these solar-powered, quick-response trailers are equipped with dual cameras, strobe lights, and wireless communication for seamless remote monitoring and control.

Built for long-term, off-grid operations, the towers provide advanced surveillance and monitoring capabilities ideal for construction sites, mining operations, public safety, law enforcement, crowd management, emergency response, transportation departments, educational institutions, and military use.

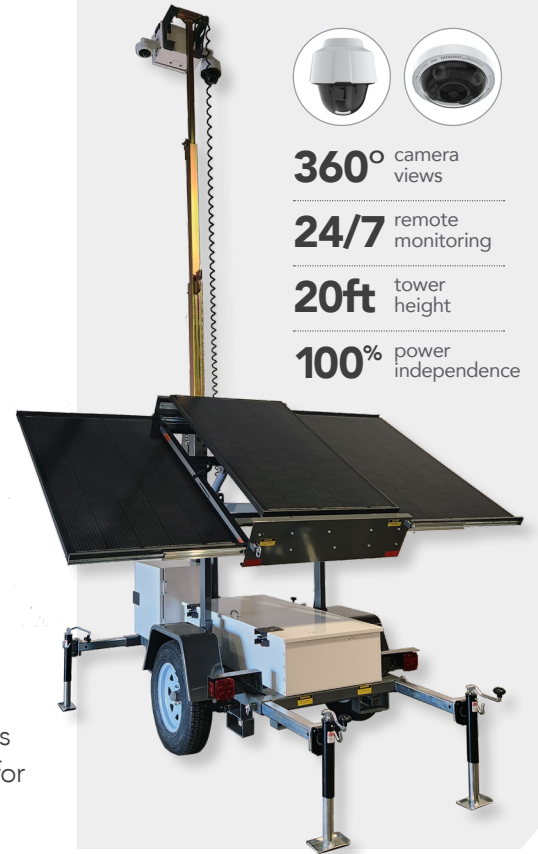

ADVANCED MONITORING

Powerful and flexible video management

Self-Monitoring

- 24/7 access to live camera feeds*
- Real-time alerts via email or text.
- Onsite recording

Central Station Monitoring

- Self-Monitoring — Plus
- Video alerts monitored by trained analysts.
- Immediate dispatch of emergency responders when necessary.

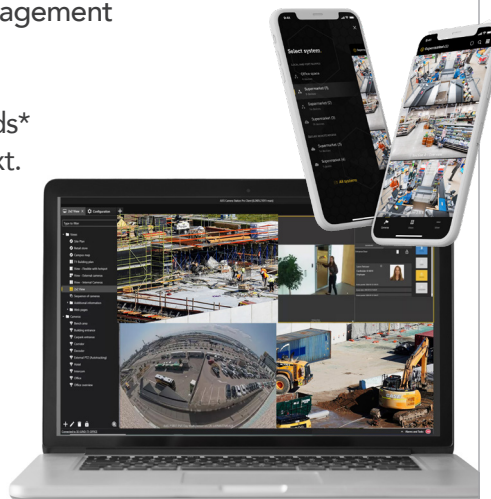

This flexible approach ensures reliable surveillance tailored to your requirements.

*24/7 remote monitoring provided by User or Third-Party partner

FEATURES

- Rapid Deployment
- Solar: off-grid operations
- High resolution PTZ
- Advanced video monitoring
- Active deterrence lights
- 24/7 live streaming
- IOS or Android mobile apps
- Live agent monitoring
- Automated alerts via SMS or email



Transportation Supply LLC
1401 Lavaca Street #40, Austin, TX 78701
(866) 930-4604
sales@trans-supply.com
www.trans-supply.com

MOBILE SURVEILLANCE TOWERS

SPECIFICATIONS

Collectors	Three 300W Panels. Polycrystalline, nested in steel frame, anti-theft fasteners
Output	24v
Collector tilt	0° to 45° via a manual crank
Solar power	900 W
Batteries	Six AGM sealed, 12 Vdc, wired as a 24-volt system
Battery capacity	600 Ah total
Charger	40A, 24v, fan cooled, external plug
Mast height	234 in (594 cm)
Deployed footprint (L x W)	129 in x 93 in (328 x 317 cm)
Travel footprint (H x L x W)	99 in x 129 in x 61 in (251 x 328 x 155 cm)
Weight (approx.)	2,250 lb (1,020 kg)
Tires and wheels	ST205/75D15 load range C
Axle	3500 lb
Hitch	2" ball coupler standard (other options available)
Draw bar	3" square tube, 3/16" wall, removable
Jacks	(4) swing type, 2000 lb ea., (1) wheel type on drawbar
Battery box	14 ga. formed steel, anti-theft, dual hidden shackle solid security locks

SURVEILLANCE EQUIPMENT

Standard Package #1 (PTZ & 360)

IR PTZ Camera - 4 MP with 30x optical zoom

PLE 360° Panoramic Camera - 12MP with 360° view

Active deterrence (strobe lights)

Standard Package #2 (PTZ & 2 Thermal)

IR PTZ Camera - 4 MP with 30x optical zoom

Thermal Cameras

Active deterrence (strobe lights)

Optional Attachments

Bullet Camera

Strobe and Siren

Network Horn Speaker

Deployed

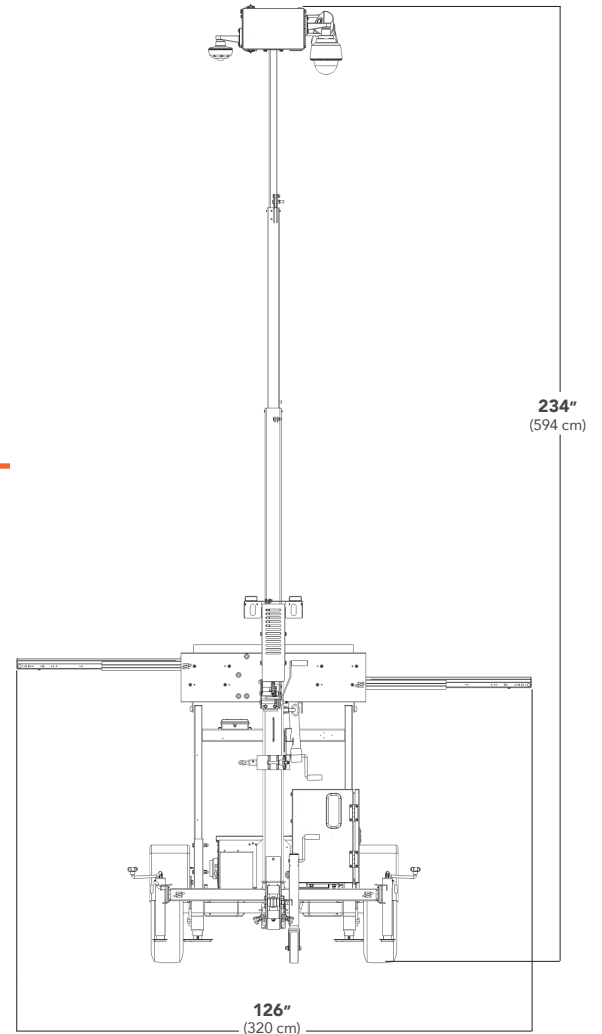

DIMENSIONS

Travel Position

