

PRODUCT SPECIFICATIONS

SAFETY BARRICADE SYSTEM MODEL #2408-50



BARRICADE SPECIFICATIONS

Barricade Type: RRM Safety Barrier Airport Model 2408-50

Color/Part Number: Safety Orange (2408SO-50), Safety White (2408SW-50), Safety Yellow (2408SY-50), Military Tan (2408MT-50), Olive Drab (2408OD-50), and Blue (2408BL-50)

Composition: UV-Resistant Polyethylene

Height: 24" / 610 mm

Length: 96" / 2438 mm

Width: 16" / 407 mm

Wall: .25" / 6.35 mm (avg)

Mass: 50 lbs. (empty) / 467 lbs. filled with 50 gal. water / 1227 lbs. filled with sand

Description: The Safety Barrier or portable barricade is a specialty barrier that is superior in strength and quality to the competition. The barriers are designed to remain maintenance free and stay in place. Since they are made with recyclable, UV resistant polyethylene plastic, they won't chip, fade, crumble or spark if struck by a metal object. This barrier, when empty, allows for deployment by just one-two individuals and thus saving the high cost of additional manpower and equipment for set-up. This barrier is also designed to hold a flashing light if desired.

LIGHT SPECIFICATIONS

360 Degree Barricade Light



Part Number: 360BX (box base) Color Options: Red, Amber/Yellow, Clear, Blue

Solar Powered
Type A/C Barricade Light



Part Number: DF002
Color Options: Red, Amber/Yellow, Blue

24" BARRIER

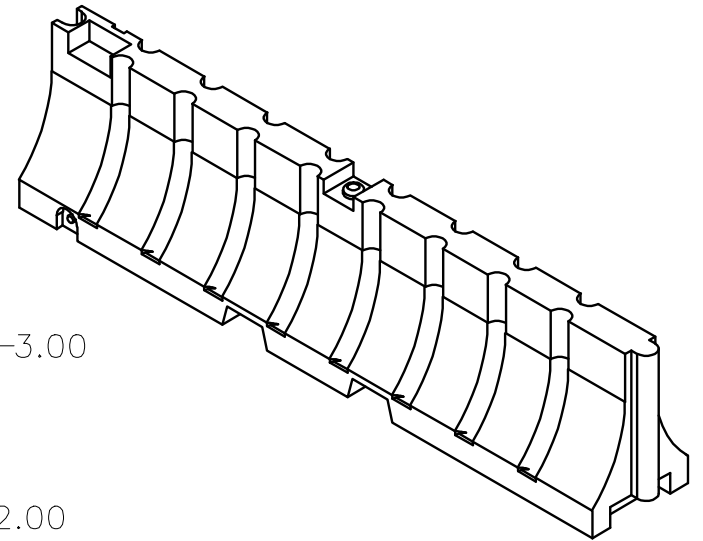
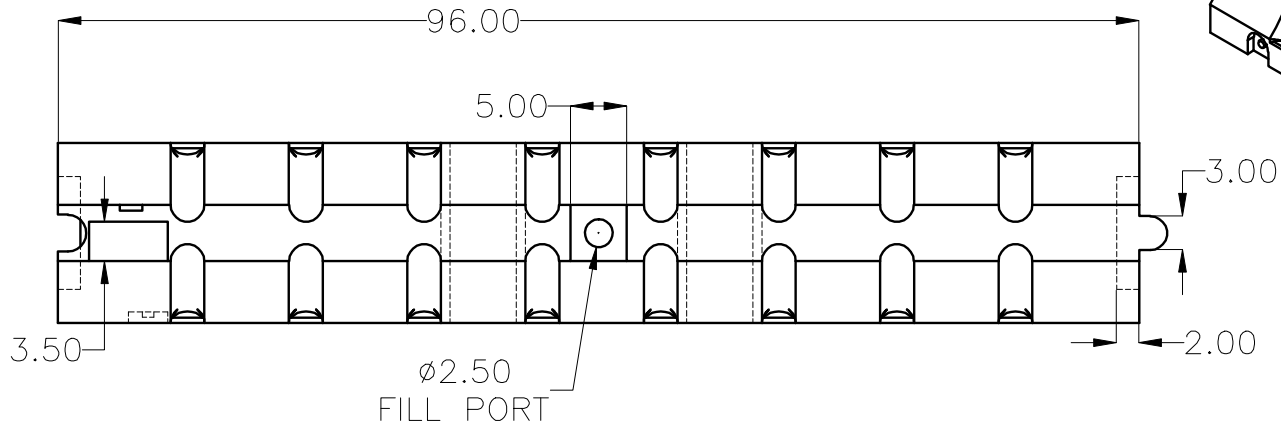

APROX. 1/4" WALL THICKNESS

